

**AIRBUS A318/319/320/321/330/340
MODEL 0851HL
PITOT PROBE**

- > **Certified on A318/319/320/321/330/340 aircraft through Type Certificate Amendment with Airbus**
- > **Interchangeable and Intermixable with existing Rosemount Pitot Probe**
- > **Enhanced de-icing performance**



INTRODUCTION

Sensor Systems, Goodrich Corporation has introduced the Model 0851HL Pitot Probe for Airbus A318/319/320/321/330/340 aircraft. This pitot was developed by Sensor Systems and Airbus to enhance de-icing performance of the current Model 0851GR Pitot Probe, while still maintaining the proven reliability of the existing probe.

The Model 0851HL Pitot Probe complies with the requirements of Airworthiness Directives 2001-353(B) and 2001-354(B) issued by the French DGAC in August 2001.

FEATURES OF MODEL 0851HL

Improved Design Features

In order to meet the Airbus extreme icing conditions specification, the Model 0851HL Pitot Probe has been designed as a replacement for the Model 0851GR. These performance enhancements were accomplished by increasing the power density in the tip region by 35% over the existing probe, and incorporating the high power density in the drain hole region to ensure proper drainage during severe icing conditions.

Form and Function Interchangeability

Since the Model 0851HL Pitot Probe has been designed to replace the existing sensor, it may be installed on any Airbus A318/319/320/321/330/340 airplane with no modifications to the aircraft required. The Model 0851HL Pitot Probe is certified fully interchangeable and intermixable with the current Rosemount Model 0851GR probe. The 0851HL pitot is also functionally interchangeable with existing pitot probes certified on A318/319/320/321/330/340 manufactured by Goodrich competitors.

Proven Performance & Reliability

The Model 0851HL Pitot Probe is based on over 40 years of experience designing and manufacturing Air Data Probes. Each pitot probe is engineered to meet the exact requirements of its specific application, and its performance and repeatability are verified by the calibration of each production unit. To ensure that pressure measurement is not degraded over the service life, Sensor Systems continues to develop robust pitot inlets that are less susceptible to damage and erosion. Extensive wind tunnel and flight evaluation data enables Sensor Systems to fully understand the effects of wear on aerodynamic performance and minimize those effects in their probe designs.

SPECIFICATIONS

Heater Power Required:	115VAC
Icing Performance:	Qualified to FAA TSO-C16 and AS 393
Pressure Connection:	Three pin quick-disconnect air fitting, Hydraflow P/N IQMI-3-54A or equivalent
Electrical Connector:	Three pin connector per MIL-C-5015

MODEL 0851HL PITOT PROBE

CONFIGURATION DRAWING

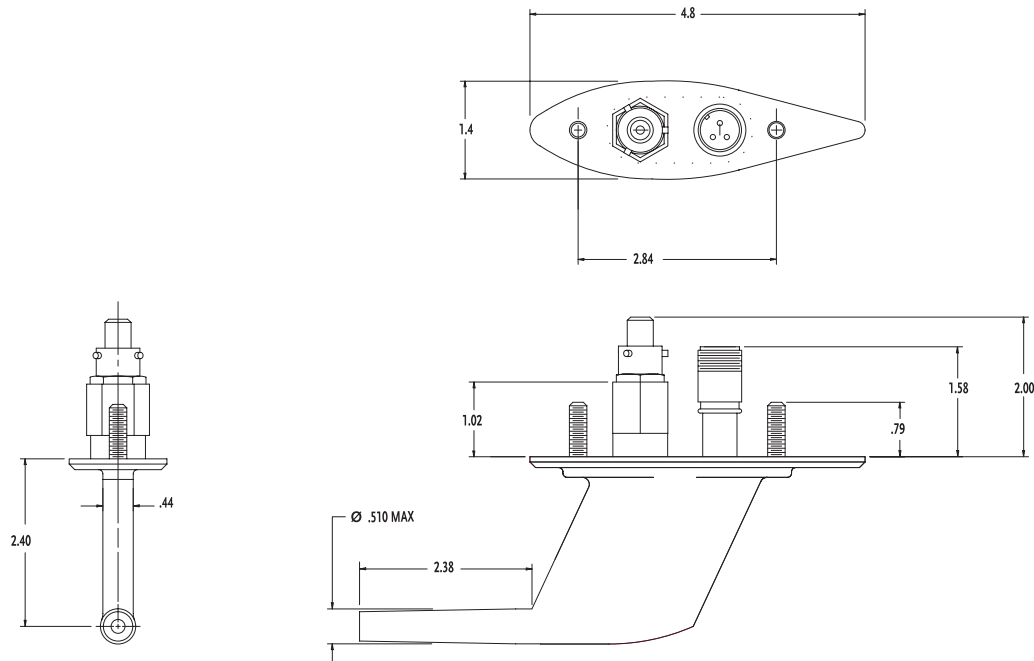

All dimensions in inches

DESCRIPTION

Sensor Systems Model 0851HL Pitot Probe is an integral part of the Air Data System of the aircraft. Sensor Systems pitot probes provide vital information for aircraft flight control. Pitot pressure measurements are used for calculating flight parameters, which include pressure altitude, airspeed and Mach number. Air data probes also provide information for secondary purposes such as engine control and cabin pressure differential.

The Model 0851HL Pitot Probes are constructed using materials with an optimum combination of strength, corrosion resistance, producibility and heat transfer characteristics. Sensor Systems pitot probes also feature a proprietary compensating heater used to de-ice the sensor in various atmospheric conditions.

FOR ADDITIONAL INFORMATION

To learn more about the Model 0851HL Pitot Probe, call Goodrich at 952 892 4000.



Sensor Systems
Goodrich Corporation
14300 Judicial Road
Burnsville, MN 55306-4898
USA
Tel: 952 892 4000
Fax: 952 892 4800

www.aerospace.goodrich.com

4004 LIT 03/02
© Rosemount Aerospace Inc., 2002
Printed in the USA

The Goodrich name, logotype and symbol are trademarks of Goodrich Corporation.